

# CONTENTS

Contents . . . . .	1
Safety Precautions . . . . .	2 - 4
Getting Started. . . . .	5
Spray pattern . . . . .	6
Distance & Pressure Tube. . . . .	7
Spraying techniques . . . . .	8
Aircap selection . . . . .	9
Latex & Viscosity . . . . .	10 - 11
Viscosity guide . . . . .	11
Cleaning . . . . .	11 - 12
Finish Problems . . . . .	13
Spray Gun Problems . . . . .	14 -15
Needle Packing & Seals. . . . .	16
Pressure Pot use . . . . .	17
Turbine Care and Maintenance . . . . .	18
Parts diagrams. . . . .	19 - 21
Spray Gun Holder . . . . .	22
Service information. . . . .	23
Warranty information . . . . .	24
CE Declaration . . . . .	Back Cover

***Please read these instructions carefully before using the equipment***



### **GROUNDING**

This appliance must be grounded. If it should malfunction or break down, grounding provides a path of least resistance for electric current to reduce the risk of electric shock. This appliance is equipped with a cord having an equipment-grounding conductor and grounding plug. The plug must be inserted into an appropriate outlet that is properly installed and grounded in accordance with all local codes and ordinances.

This appliance is for use on a nominal 120-volt circuit and has a grounding attachment plug that looks like the plug illustrated. Make sure that the appliance is connected to an outlet having the same configuration as the plug.

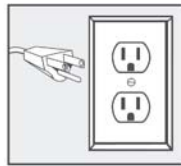

**Please Note\*** For UK, Australia, Asia etc. your voltage will be 220-240v. Check the label on the base of the turbine to ensure your unit is at the correct voltage for your location.



### **ELECTRIC SHOCK HAZARD**

**Improper connection of the equipment grounding conductor can result in the risk of electric shock.**

- Check with a qualified electrician or service person if you are in doubt as to whether the outlet is properly grounded.
- Use only a 3-wire extension cord that has a 3-blade grounding plug and a 3-slot receptacle that accepts the plug on the product.
- An undersized cord results in a drop in line voltage and loss of power and overheating.
- Do not modify the plug provided with the appliance. If it will not fit the outlet, have a proper outlet installed by a qualified electrician.
- To reduce the risk of electric shock or injury, do not expose to rain.
- Never allow unit to freeze.

- Always store the unit inside in a dry location. Store on the floor if in a basement setting.
- The operator must wear shoes and the floor must not be wet.



### **FIRE AND EXPLOSION HAZARD**

**Turbine must not be used in an area contaminated by volatile or flammable materials since sparking can be expected in the normal operation of the motor. This could ignite the contaminants causing a dangerous explosion.**

- Do not spray flammable or combustible materials near an open flame or sources of ignition such as cigarettes, motors, and electrical equipment.
- Keep spray area well-ventilated. Keep a good supply of fresh air moving through the area. Keep turbine in a well ventilated area.
- Do not spray turbine.
- Turn off and disconnect power cord before servicing equipment.
- Do not smoke in the spray area.
- Do not operate light switches, engines, or similar spark producing products in the spray area.
- Keep area clean and free of paint or solvent containers, rags, and other flammable materials.
- Fire extinguisher equipment shall be present and working.
- Sprayer generates sparks. When flammable liquid is used in or near the sprayer or for flushing or cleaning, keep sprayer at least 20 feet (6 m) away from explosive vapors or spraying area.
- Ensure ground prongs are intact on sprayer and extension cords.
- Always disconnect unit from main supply when filling the paint container.



### **TOXIC FLUID OR FUMES HAZARD**

**Toxic fluids or fumes can cause serious injury or death if splashed in the eyes or on skin, inhaled, or swallowed.**

- Read MSDS (Material Safety Data Sheet) to know the specific hazards of the fluids you are using.
- Always wear appropriate gloves and eye protection
- Always wear a respirator or mask. Read all instructions of the respirator or mask to ensure that it will provide the necessary protection against the inhalation of harmful vapors. Please also check with the local jurisdiction.

- Paint, solvents, insecticides and other materials may be harmful if inhaled.
- Store hazardous fluid in approved containers, and dispose of it according to applicable guideline.
- Do not stop or deflect fluid leaks with your hand or body.



### **EQUIPMENT MISUSE HAZARD**

#### **Misuse of equipment can cause serious injury or death.**

- Never aim the spray gun at another person or animal. In the event of injury, seek expert medical advice immediately.
- Do not operate or spray near children. Keep children away from equipment at all times.
- Do not overreach or stand on an unstable support. Keep effective footing and balance at all times.
- Stay alert and watch what you are doing.
- Do not operate the unit when fatigued or under the influence of drugs or alcohol.
- Do not kink or over-bend the hose.
- Do not use the hose as a strength member to pull or lift the equipment.
- Do not cover turbine case as this will restrict air to the intake and result to overheating and premature failure of the motor.
- Do not carry turbine while spraying.
- Check the hose, hose connectors and power cord daily. Any worn or damaged parts should be replaced immediately.
- Use only genuine Fuji Spray replacement parts.
- It is normal for the turbine air outlet (manifold) to become hot during use, please allow your Fuji Spray turbine to cool for a few minutes before removing the hose from the turbine manifold.



#### **Prop 65 Warning for California Residents**

**WARNING:** This product may contain chemicals known to the State of California to cause cancer, birth defects, or other reproductive harm.

## GETTING STARTED

Please register your Fuji Spray Product at [www.fujispray.com/product-registration](http://www.fujispray.com/product-registration)

NOTE: Throughout this Manual we have used the generic word 'Paint' to describe all and any coatings. Please substitute the word 'Paint' for whatever finish or coating you are spraying.

Your Fuji Spray Gun has been adjusted at the factory and is ready for spraying. To clean out any impurities that may have accumulated during assembly or shipping, we recommend spraying a small quantity of clean paint thinner through the gun. Before tackling any serious spraying, experiment with the Gun on a scrap piece of wood until you become familiar with all the controls.

## HOSE CONNECTION

Connect the Hex Nut at the end of the Hose (Female Connector) to the Turbine Air Outlet. **Tighten this Nut lightly. Overturning could cause the internal Manifold to rotate and break the internal Seal to the Motor.** A Male Quick Connect Coupler 2046M is available as an accessory for the connection to the turbine.

## AIR CONTROL VALVE

The Air Control Valve 2032 is located on the Hose next to the brass Quick-Connect. It provides you with a means of controlling the air flow through the Gun. It offers you fingertip control when you need it to reduce bounceback and overspray. It is important to remember that the Air Control Valve - is the '**last in the chain**' of operations after...

- 1) Thinning the paint
- 2) Adjusting the shape and size of the spray pattern
- 3) Adjusting the flow of paint through the Gun.

After performing these operations, you should spray a few passes onto a scrap piece of plywood or cardboard. This will allow you to determine if the paint levels nicely. Once the Gun is producing a perfect finish with full air, you may then experiment with turning the air down until bounceback is reduced to a minimum. However, if orange-peel results, you have no option but to turn the air up again a slight amount.

## PLASTIC DIAPHRAGM

The 1 Quart pressurized Cup has a plastic Diaphragm 2038 (not found in the Gravity Spray Gun). This Diaphragm prevents paint from entering the Pressure Tube 2024. The small air hole in the Diaphragm should not be placed directly below the air hole in the Nipple. Position the Diaphragm hole to the rear of the Cup. The Spray Gun can be turned to different angles when spraying but never turned more than horizontal.

## CHANGING THE SHAPE OF THE FAN

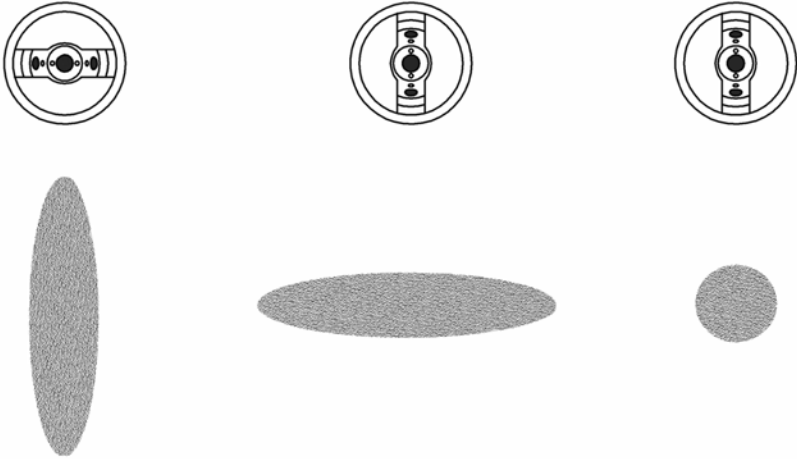

A) Loosen the collar 6094. Turn the air cap 6093 to the horizontal position then re-tighten to collar to lock it into place. This setting produces a vertical spray pattern. This pattern is used more than any other by experienced spray painters.

B) Setting the air cap in a vertical position produces a horizontal spray pattern. The horizontal fan pattern is the most useful for painting vertically such as a doorframe.

## CHANGING THE SIZE OF THE FAN

To produce a smaller round fan pattern, turn the pattern control knob 6073 counter-clockwise. Because the spray pattern size is now much smaller, **you must turn down the amount of paint** spraying through the nozzle (fluid knob 8029). If you do not do this, you will get runs.

To set the fluid output, simply turn the fluid knob 8029 counter-clockwise for more 'paint' and clockwise for less. Once you set the fluid to your liking, you can leave it in this position - unless of course, you change the size of the fan pattern.

For the very smallest pattern (less than about 1 1/2"), you must move the gun closer to the workpiece - but don't forget to reduce the amount of paint at the fluid knob (rear of gun) when you do this.

## SPRAY GUN DISTANCE

The spray pattern is fan-shaped, so for a larger sized fan you do not have much choice - you will be at or close to the **maximum 8" distance**. It's impossible to produce a large spray pattern if you hold the spraygun too close to the object - there is no room for the fan pattern to expand.

As you move closer with the gun, the fan will become a smaller size. So for instance, what was 10" wide at a distance of 8" becomes about 2" fan at 2" distance.

When you want to paint something that is, let's say, 2" across and 6ft long - you will find it much easier to follow the object if you move the gun closer. This will give you the ability to control your pass from side to side properly without wandering all over the place. Plus it will reduce overspray. Imagine spraying 1/2 chair spindles from 8" away with a spraygun when you don't have bristles (as you do with a brush) to help guide you - it's very difficult. So simply adjust the pattern to be smaller and cleaner (pattern control knob 6073) and move in close until the fan is the exact same size as the spindles. Once you are close, you will be able to guide the spraygun easily and it will not be as important to have a completely steady hand.

As an aside - it is usually not possible to bring the sprayhead close to the object with other methods of spraying (high-pressure for instance). Doing so would produce bounceback. The pressure is much less with turbine HVLP so this is not a problem.

## THE PRESSURE TUBE

When spraying, never turn the gun upside down. The cup should never be higher than horizontal. The 1 Quart cup must always be lower than the gun. (On the gravity gun, it's the opposite, the cup must be higher than the gun - at least no lower than horizontal).

Upon stopping spraying for any reason, first turn off the turbine. Disconnect the hose and then carefully open the cup to release pressure. It's best to hang up the gun - use any type of hook or rod for this.

Do not stand the gun on a bench or even the floor because it will always be prone to falling over which could damage the spraygun and cause paint to flow up the pressure tube and into the spraygun.

Any paint in the pressure tube 2024 or nipples 2023 the tube is attached to, causes reduced amounts of paint through the gun. This is because the cup pressure is too low. Air is being restricted through the nipples by the paint blockage. The symptom will be little or no paint and the reason will always be the nipples or pressure tube being clogged with dried paint. We suggest always having extra pressure tubes on hand.

## ACTUAL SPRAYING TECHNIQUES.

The spraygun should be held perpendicular to the surface at all times. HOLD THE GUN NO MORE THAN 8" (20cm) AWAY FROM THE SURFACE TO BE PAINTED. But closer is ok.

### CORRECT METHOD

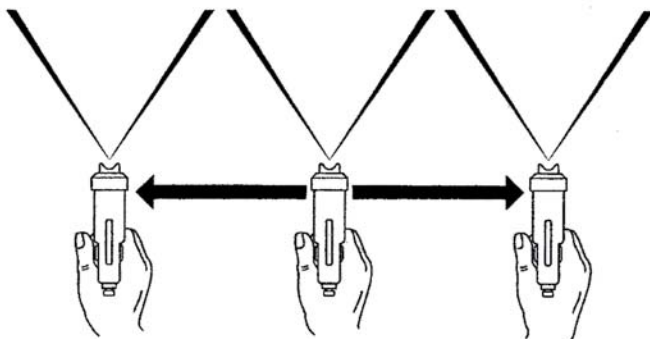

Start moving the spraygun in the direction you want to spray and press the trigger. Between each successive pass, overlap by about a quarter.

### INCORRECT METHOD

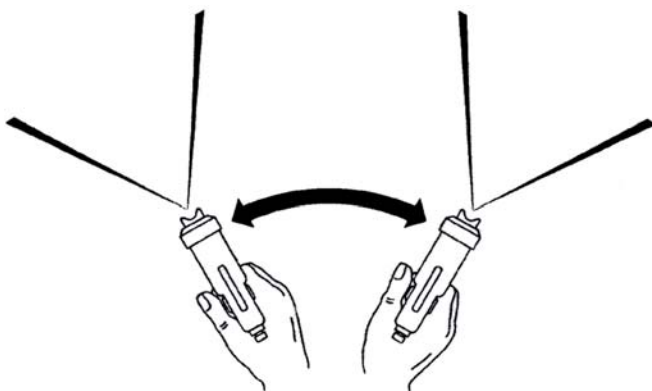

**Never, for any reason, point the spraygun directly at the face, or head of a person.**



## AIRCAP SET SELECTION

The fluid nozzle 6082 and needle 8020 MUST always match exactly. Size No.4 is standard with all Fuji sprayguns. No. 3 or No. 4 can be used for any type of fine-finishing application. The difference between the two is that the #4 allows for more fluid output. This is desirable when spraying fast drying lacquers. It allows you to spray faster and wetter to obtain better leveling of the finish. 4 additional setups are available as accessories. Generally speaking, the quality of atomization and finish reduces as you go to the larger size setups (No.5 and 6).

### AIRCAP SET - Part 8050

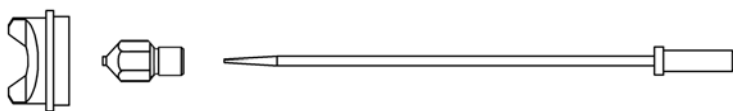

**If you do not intend on spraying walls & ceilings then the only two setups you would ever need would be the #3 Fine and Standard #4.**

**No. 2 (Part 8050-2)** .7mm (.027") FINE OUTPUT

SHADING, STAINS,

**No. 3 (Part 8050-3)** 1mm (.039") FINE OUTPUT

WATER-BASED LACQUERS, ACRYLICS, POLYURETHANE, STAINS.

**No. 4 (Part 8050-4)** 1.4mm (.055") MEDIUM OUTPUT - STANDARD

Similar to No. 3 but more coverage. Best for AUTOMOTIVE ENAMELS, NITROCELLULOSE LACQUER and LATEX for a finer finish. Also ideal for VARNISHES, PRIMERS, OIL-BASED PAINTS and STAINS.

**No. 5 (Part 8050-5)** 1.8mm (.070") HIGH OUTPUT

Larger surfaces, thick layers, spotted effects. SEALERS, VARNISH, POLYURETHANE, OIL BASED PAINTS, ENAMELS, EPOXY, PLASTIC, ADHESIVES, FLOOR PAVING PAINTS, LATEX, ETC.

**No. 6 (Part 8050-6)** 2.2mm (.086") EXTRA HIGH OUTPUT

Very heavy flows, fast coverage. STONE FINISH PAINTS, TEXTURE COATING, INDUSTRIAL PRIMERS, MULTI-FLECK PAINTS, LATEX (on walls, ceilings) ETC.

## A WORD ABOUT LATEX

Although latex paint was never originally intended to be sprayed, a professional finish can be achieved by following a few simple rules. (Please do not confuse latex with the newer water-based coatings). For work such as cabinetry or trim, our equipment can be used successfully with latex paint. The latex will have to be thinned with **WATER** - approximately **20-30% depending on the brand of paint**. And to improve the finish even more, you can use an additive that will slow down the drying process so that the paint levels out nicely. One product available is FLOETROL from the FLOOD Company in Ohio. In the USA Call 1-800-321-3444 for your nearest supplier. (In the U.K. 0845-0618899).

The ideal Aircap size setup is the #4 for household trim, louver doors etc. The Latex paint should be 'finish-quality' and not a cheaper grade.

When spraying Latex, please adjust the fluid knob to limit the paint to a finer spray. This will increase the ratio of air to paint and result in better atomization and a beautiful finish. (Factually speaking, it doesn't increase the ratio of air to paint but does the opposite - it allows the air atomizing power to work on less paint thereby improving the quality of atomization). Also, it is usually helpful to remove the air control valve so that more air passes through the spraygun. Finally, adjust the pattern to a maximum size of 8" - 9" (20cm) - smaller is ok.

Although it is possible to use our equipment for house painting (walls), and many end users do, we feel that an airless gun or power roller is better suited for that kind of job. However, if you decide to do this kind of work, you will need the #6 Aircap set.

## VISCOSITY

Follow the viscosity guide chart. You will eventually learn to thin the material by experience. Traditionally, lacquers were thinned 50/50 even for high pressure spraying but this much thinning is not necessary. However, coatings manufacturers are reformulating constantly so it is always advisable to check with them. Thinning a product excessively causes more overspray as well as runs. Stringent air quality controls in some geographic locations may prohibit reducing by more than a certain percentage. Please check with the local jurisdiction in this matter.

Remember, when you buy a can of paint, lacquer, polyurethane, varnish etc. over the counter, it will most likely be formulated for brushing. That means, it will be too viscous (thick) and will require thinning to spray successfully. This is true even when spraying is mentioned on the label of the can. Check with the manufacturer of the coating to obtain advice on thinning their product.

## VISCOSITY GUIDE

To test the viscosity of the paint material, fill the viscosity cup to the brim and time how long it takes for the liquid to empty out through the hole. We recommend you experiment to find the ideal viscosity for your application and record the information for the next time. The Fuji 3050 Viscosity Cup is made to the exact same specs as the Ford #4 Cup (but not certified).

Always check with the manufacturer of the coating for assistance in thinning for spraying. If their product is only designed to be brushed, they may not be too helpful. But remember that any type of coating can be sprayed if it is thinned correctly and you have installed the ideal aircap set.

The chart below illustrates how many SECONDS it should take for the material to flow out of the viscosity cup. This is only an approximate guide.

Auto Cellulose	18 - 20	Primers	30 - 40
Lacquers	18 - 20	Sanding Sealers	20 - 22
Enamels	20 - 25	Stains	Undiluted
Latex	20 - 30	Creosote	Undiluted
Oil-based	20 - 25	Polyurethanes	20 - 25

We suggest thinning around 25% to begin with but this may contravene the air quality control laws for your location. The solvent used for thinning is usually the solvent mentioned on the can (instructions for 'cleaning the brushes'). However, please check with the coatings manufacturer.

HVLP spraying is more friendly to the environment than most methods of spraying. It reduces appreciably the amount of unnecessary misting and fogging (overspray) associated with high-pressure spraying. Spraying with Nitrocellulose lacquer can be **hazardous. The lacquer, fumes and overspray are toxic, flammable and explosive.** If spraying must be done inside an enclosed area, **ventilate well.** Spray close to an open window or door and situate a fan to draw out the fumes (an explosion-proof motor and explosion proof lighting will be necessary). PLEASE CHECK WITH THE LOCAL AUTHORITY HAVING JURISDICTION ON THIS MATTER.

## CLEANING

To clean the gun after each use, empty all paint from the cup. Use a solvent soaked rag to clean the residue in the cup. Then, spray some clean solvent through the gun into a clean rag (to avoid filling the room with unnecessary spray) or a bucket. Repeat until the inside of the fluid passages in the gun, metal fluid tube etc. are clean. Use the wet rag to wipe off the aircap and tip of the fluid nozzle. The Aircap can be soaked in thinner.

Do not restrict the fluid nozzle when cleaning - this will drive thinned paint up the pressure tube and into the spraygun which is undesirable.

If this type of cleaning is done while the paint is still wet in the gun, it should be all that is necessary to keep the gun clean enough for next time. Do not leave liquids in the cup overnight or for long periods. **The Gravity Gun can be cleaned without hooking up to the hose. Simply wind out the fluid knob all the way and pull the trigger - the thinner (solvent) will stream out of the fluid nozzle. Repeat until clean.**

PLEASE DO NOT USE A WIRE BRUSH OR ANYTHING METAL TO CLEAN THE GUN OR CUP AS THIS WILL CAUSE DAMAGE.

**DO NOT disassemble the cup assembly - threads in your cup have been sealed at the factory to prevent leakage under pressure.**

The standard 1 quart (1000cc) cup can be used with most coatings (including water-based). Also available as an accessory is our 2041T teflon-coated cup.

**CAUTION: Never soak the complete spraygun in solvent** as this removes the grease from the parts and distributes thinned paints throughout the air passages. It could also damage internal parts such as the spindle valve 8021 or valve seals 8025. It may however, be necessary sometimes to soak the aircap 6093 and nozzle 6082. **You may soak only the metal parts in solvent and clean with the soft bristle cleaning brush 9045.** To reassemble, first oil or grease all moving and threaded parts.

**CAUTION: Do not store the gun with the cup clamped down hard as this will cause the gasket to flatten out. Do not lay the gun down on its side with liquid material in it.**

## **CLEANING FLUID COMPONENTS**

All Fuji fluid components in the spray gun are manufactured from stainless steel. To clean, flush solvent through the spraygun while the paint is still wet inside the gun.

For a more thorough cleaning, remove all parts at the front of the barrel. (collar, aircap, fluid nozzle etc.) Also remove the needle (from the rear of the gun). Please note\* the parts behind the nozzle are not removable. The fluid coupler (where the cup assembly attaches) is not removable. If necessary, use the supplied cleaning brush 9045 wetted with solvent to remove paint particles from inside the fluid coupler and from the area where the nozzle was installed. **Please do not soak the whole gun in solvent**, this should never be necessary and it could damage the valve assembly and valve seals.

The cup assembly can also be removed by loosening the swivel nut at the top of the fluid tube. Upon re-installation, please do not overtighten the swivel nut - it is basically a hollow nut. If you apply extreme torque, you can cause damage to the nut.

## FINISH PROBLEMS

**ORANGE PEEL** - If the finish is rough and resembles orange peel then the material is too thick. (Or perhaps you have the air control valve turned down - please check that it is fully open). The 'paint' will not atomize properly and the surface will be spotty. To remedy this, add more thinner (or appropriate solvent). For fast drying products such as lacquers, you may also want to add a lacquer retarder. This will slow the drying time allowing the material to flow out and level nicely.

Retarders are available for other coatings too, such as Penetrol for oil-based paints or Floetrol for latex house paints. These products go under different names such as Flow-Out Additives etc. Please check with the coatings manufacturer.

NOTE: With the newer water-based materials 'orange peel' is usually a result of spraying on too thick a film. **Try spraying an extremely THIN FILM, but still WET coat.** With most other coatings, orange peel is caused by material being too thick or not enough atomizing power. This is why we suggest leaving the air control valve fully open when experimenting with a new coating material, otherwise it will cause confusion. If the the air control valve is fully open (or perhaps removed for Latex spraying) then orange peel can only be one cause - the material is too thick and must be thinned.

**GRITTY FINISH** - If the material is too thin, it is likely to run or be over-atomized, producing a rough gritty finish. Try thinning the product less and spraying a wetter coat.

**BLUSHING** - Blushing is the common term used when the finish looks cloudy and white (sometimes also called blooming). It is caused by moisture and is especially a problem when operating high pressure spray equipment. The moisture comes from the compressor. This problem does not usually occur when using the Fuji turbine because the air from the turbine is warm, dry and uncontaminated. However, it is possible on very humid days to encounter slight blushing. Using a retarder will often allow moisture to escape, preventing the milky look.

**FISH EYES** - If you are refinishing furniture or pianos, fish eyes could become a problem. The cause is usually silicone or oil from polish which has been liquified by the paint stripper that has now soaked into the bare wood. This silicone prevents the lacquer from adhering to the wood. One way to sometimes correct this is to seal in the silicone by misting on two or three light coats of lacquer. Then spray on a regular wet coat. We *do not* recommend the use of a product known as 'Fish-Eye Drops' which is essentially liquid silicone. Silicone will only contaminate the gun even further. Anything that comes into contact with the silicone becomes contaminated - such as; rags, aprons, bench tops, gloves.

## SPRAYGUN PROBLEMS

### NO PAINT (OR VERY LITTLE PAINT)

#### THIS IS THE MOST COMMON PROBLEM ENCOUNTERED -

The air passing through the plastic tube 2024 to pressurize the cup is blocked. This means that either the tube itself, the check valve, or one of the two nipples 2023 is blocked. A pipe cleaner can be used for cleaning the hole in the nipple. Please see more info on the pressure tube' - **Page 5**

- Pressurizing tube and/or nipples are blocked - COMMON
- The cup is not tightened down sufficiently by the quick-release lever or the cup gasket 2036 is worn and leaking air
- The cup is empty
- The metal fluid tube is blocked with paint - rare
- The fluid coupler is blocked with paint - rare

### UNEVEN SPRAY PATTERN

One of the holes in the aircap may be blocked. Or, the paint could be dirty and is partially blocking the fluid nozzle. Remove the aircap and clean by soaking in solvent and using the soft bristle brush or a rag. NEVER use metal objects to clean holes in the aircap.

### LEAKAGE

If paint material comes out of the fluid nozzle **without** pulling the trigger...

- The needle is not seating in the fluid nozzle properly
- The needle packing may be too tight preventing the needle from moving
- Foreign matter could be trapped between the needle and fluid nozzle
- The needle or fluid nozzle could be damaged or worn
- Loose fluid nozzle
- Wrong nozzle size installed

### CUP LEAKS

- Oil above and below the lever to smooth the lever action
- Change gasket/diaphragm - oil lever first to check
- Leak around nipple - use Loctite to seal
- Leak around side pins - use Loctite to seal
- Leak through lid - remove nut under lid - use Loctite

## **THE TRIGGER IS SLUGGISH**

- The needle packing is too tight - see ADJUSTING THE NEEDLE PACKING. Page 14
- Bent needle
- The valve seal 8025 is damaged - replace

## **POOR SPRAY PATTERN**

- Damaged needle or nozzle
- Nozzle is clogged
- Air holes in air cap clogged
- Aircap screwed in too tight
- Gun too far from surface (max. 8" - 20cm)

## **PAINT AT THE AIR NOZZLE HOLES**

- The fluid nozzle is loose and material is leaking around it - tighten with a adjustable wrench or 7/16" socket.
- Paint is entering the gun via the pressure tube (very rare) and being blown through the barrel to the aircap - see HOW TO PREVENT PAINT ENTERING THE PRESSURE TUBE. Page 4

## **GUN SPRAYS IN A PULSATING MANNER**

- The needle packing has worn a little or is loose. Tighten
- The cup is almost empty
- The cup lid is not tight - air is escaping
- The clear plastic pressure tube is leaking air. Replace
- The pressure tube and/or nipple is clogged. Clear or replace
- Gravity gun - turn the collar IN to alleviate back-pressure

## **EXCESSIVE OVERSPRAY**

- The spray pattern size is too large for the item you are spraying
- The gun is being held too far away - should be 8" max. (20cm)
- Trigger on and off as you pass over the edges of the item
- The product is too thin - try thinning less
- Reduce the air by turning the air control valve to the point where overspray is minimized but the finish still looks good
- For ideal and comfortable spraying conditions, you should install an extraction fan.\* If you are spraying a flammable, combustible product such as nitrocellulose lacquer, you must install an explosion-proof fan (and explosion-proof lighting and switches)

**\* Please check with the local jurisdiction on this matter.**

## ADJUSTING THE NEEDLE PACKING

The needle packing must be tight enough to prevent any leakage of paint material. It should however, allow the needle to glide smoothly through it. If the packing is too loose, you will see a small amount of paint where the needle passes through the small needle packing nut 8008. Using the supplied wrench, gently **tighten** the nut. This is a good time to apply a spot of oil to the needle where it passes through the packing nut. This is a sensitive adjustment so please adjust only 1 or 2 degrees at a time.

If the needle packing is too tight, paint will spurt out of the fluid nozzle 6082 when you release the trigger. To correct, **loosen** the needle packing nut 8008.

Like all spraygun manufacturers, we use 'stock' stainless steel rod for the needle. This rod can differ in diameter slightly with each production run. So if you change a No. 3 for a No. 4 needle, one could be a slightly oversized diameter and one slightly undersized. This may necessitate adjusting the needle packing.

## THE SPINDLE VALVE ASSEMBLY

The spindle valve assembly 9003 can be removed as follows.

- 1) Remove the fluid knob 8029, spring 8019, and gently pull out the needle assembly 8020.
- 2) Turn out the fluid screw nut 8031 (a socket is preferable to a wrench).
- 3) Remove the spring 8026 and gently pull out the spindle valve assembly 9003.

To replace, reverse the procedure being careful to center the spring 8026 onto the spindle valve 8021. Also, before tightening in the fluid screw nut please ensure that the spindle is centered in the seal. The end of the spindle is visible through the hole in the fluid screw nut.

## THE SPINDLE VALVE SEALS

Removal and replacement of the spindle valve seals is simple. Any thin, flat tool such as a screwdriver can gently pry out the seal. To replace, firmly push the seal into place. Small leaks of air are not important and will have absolutely no effect whatsoever on the atomization process.

The seals are designed to be durable and long-lasting under normal working conditions. We do not recommend the practice of dunking the whole spraygun into a container of solvent. This may damage the valve and valve seals.



## **PRESSURE POT USE FOR 4-STAGE OR 5-STAGE TURBINE**

If you use a 4-stage Turbine or higher, a compressor is NOT needed to pressurize the Fuji Spray 2 Qt. Pressure Pot.

The Fuji Spray 2 Qt. Pressure Pot Assembly 5432 has unique features. These features combined with additional pressure from the Fuji Spray 4-stage Turbine, allows the user to connect the larger capacity pot to the Turbine system without the need for a compressor.

To connect the Fuji Spray 2Qt. Pressure Pot Assembly, remove the cup assembly and the pressurizing tube 2024 from the spraygun.

For XPC - Connect your material line (fluid hose) to the fluid coupler 8005 on the gun.

For GXPC – You will need to order an additional L-Fitting 9060. Attach this L-Fitting to the G-Fluid Coupler 9051 and connect your material line (fluid hose) to the other end of the L-Fitting.

You must block off the air that would normally go from the gun to the cup assembly. This nipple can be covered with Nipple Cap 5411.

## **PRESSURE POT USE FOR 3-STAGE**

If you use a 3-stage Turbine or lower, a compressor IS NEEDED TO PRESSURIZE THE POT.

PLEASE NOTE: The Fuji Spray 2 Qt. Pressure Pot Assembly 5432 has been designed for Turbine use and is NOT compatible with a compressor. However, you are able to hook up a standard 2Qt. Pressure Pot with a compressor.

To connect to a Pressure Pot, remove the cup assembly and the pressurizing tube 2024 from the spraygun.

For XPC - Connect your material line (fluid hose) to the fluid coupler 8005 on the gun.

For GXPC – You will need to order an additional L-Fitting 9060. Attach this L-fitting to the G-Fluid Coupler 9051 and connect your material line (fluid hose) to the other end of the L-Fitting.

You must block off the air that would normally go from the gun to the cup assembly. This nipple can be capped with Nipple Cap 5411.

If using a 2-stage or 3-stage Turbine, we recommend the use of a compressor. Set the compressor to between 6-8 PSI. This is enough to push the paint material up to the gun. For spraying at greater heights (over 8 feet), more fluid pressure may be necessary. The fluid pressure should never be set at more than 20 PSI. If you find a higher pressure is needed, we advise you to check the material hose for paint blockage.

## TURBINE CARE AND MAINTENANCE

### FUJI SPRAY PLATINUM SERIES TURBINES

All PLATINUM Turbines are built with the Fuji Spray Heat Dissipation Box™. Excess heat is channeled directly to this outlet located at rear of the case.

**Note:** There is no maintenance required for the Heat Dissipation Box™.

### Q5 PLATINUM VARIABLE SPEED CONTROL DIAL

The Q5 PLATINUM Turbine is installed with Variable Speed Control Dial on the front of your Turbine case. This feature offers the ability to adjust the psi to the optimum needed to perfectly atomize your coating and yet reduce the overspray/bounceback to an absolute minimum.

Please refer to “[www.fujispray.com/technical](http://www.fujispray.com/technical)” or the Fuji Spray “FAQ” page. Here you will find detailed instructions on the most efficient way to use this Dial.

### FILTER(S)

It is important to clean or replace your filters regularly. Operating the Turbine unit with clogged or dirty filters will cause the Turbine to overheat and result in premature failure. The Fuji HVLP Turbines have either 1 or 2 Filters. To remove, simply pull the Filters out from Filter Enclosure. Wash in warm soapy water and **dry** before replacing.

All Fuji Filters are a friction fit. The Filter must fill the entire Filter Enclosure.

**NOTE:** Mini-Mite GOLD Turbine has two **square** filters, fine and coarse. The fine Filter is installed to the left side and the coarse to the right side (as seen looking at the front of the Turbine where the Hose is connected).

**Cleaning your filters regularly is essential to maintaining your Turbine. It is always a good idea to have a spare pair of filters on hand.**

Turbine Filter part numbers:

- Mini-Mite GOLD Turbine (square shape filters) - Part # 4009-2
- Mini-Mite PLATINUM Turbine (semi-circle shape filters) - Part # 7224-2
- Q GOLD and PLATINUM Turbine filter- Part # 5029

All HVLP Turbines are designed for intermittent use. When taking a break between coats or stepping aside to refill your cup, it's good practice to turn the Turbine off during this time. This allows the machine to cool off.

When spraying, always ensure that the Turbine unit is at least 15 feet away from spray project and in a well ventilated area. This will prevent any overspray or debris being ingested into the Turbine. Failure to do this may cause the filters to clog, resulting in damage to the internal motor.

If you experience a problem with your Turbine unit, please **DO NOT** try to open and service the Turbine yourself. Contact us for technical assistance.

If it is an issue of no power, check your power outlet. Also, try re-setting the Breaker on the back of the turbine by pressing it once.

### CUP ASSEMBLY 2042

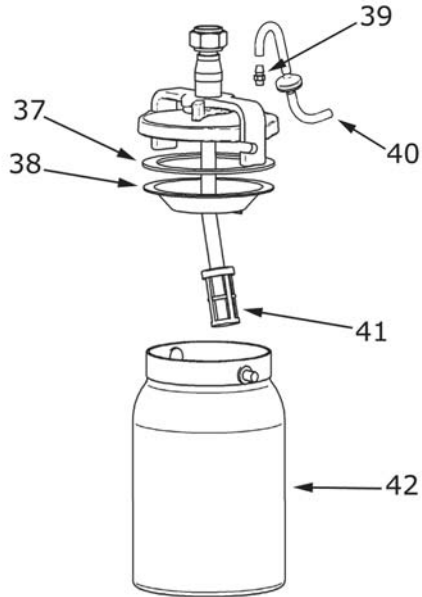

### GRAVITY GUN PARTS

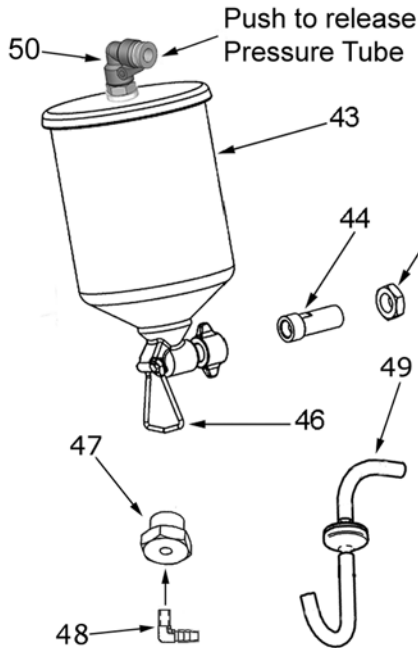

ITEM	PART	NAME
37	2036	Cup Gasket
38	2038	Diaphragm
39	2023	Nipple
40	2024	Pressure Tube
41	9044	Paint Strainer
42	2041	1 Qt. Cup
43	9850	Gravity Cup
44	9051	G-Fluid Coupler**
45	8067	Jamb Nut-G**
46	9000	Fold-Down Stand
47	2020	Nipple Adaptor
48	2021	90 Degree Nipple**
49	2024-L	Pressure Tube-L
50	9852	Plastic Fitting

Please Note: Parts shown with \*\* are not removable

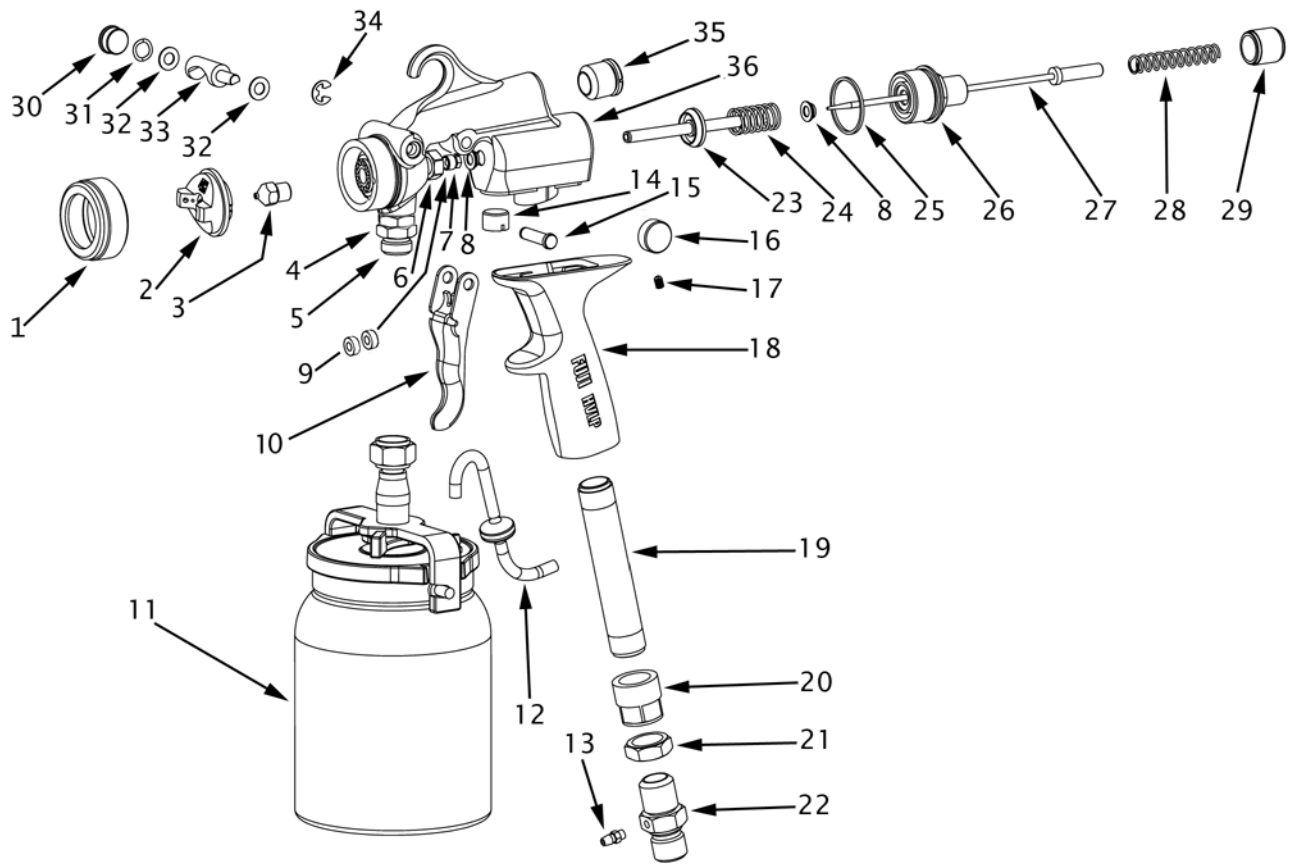
**FUJI XPC SPRAY GUN**

ITEM	PART	NAME	ITEM	PART	NAME
1	6094	Collar	19	8047	Handle Tube **
2	6093	Aircap	20	8035	Handle Tube Nut
3	6082	Fluid Nozzle	21	8033	Jamb Nut
4	7006	Jamb Nut **	22	8034	Hose Connector
5	8005	Fluid Coupler **	23	9003	Valve Assembly
6	8006	Jamb Nut **	24	8026	Valve Spring
7	8008	Needle Packing Nut	25	8030	Fluid Screw Nut Seal
8	8025	Valve Seal	26	8031	Fluid Screw Nut
9	8007	Needle Packing (2)	27	8020	Needle Assembly
10	8040	Trigger	28	8019	Needle Spring
11	2042	Cup Assembly	29	8029	Fluid Knob
12	2024	Pressure Tube	30	6074	Air Plug
13	2023	Nipple	31	6080	Wave Spring
14	7012	Threaded Plug **	32	6077	Shaft Washer
15	8041	Trigger Barrel	33	6075	Air Deflector
16	6073	Pattern Control Knob	34	8042	Retaining Ring
17	6072	Allen Screw	35	7007	Rear Barrel Plug
18	8046	Handle	36	6060	Gun Body

Please Note: Parts shown with \*\* are not removable

## GUN HOLDER & FILLING STATION

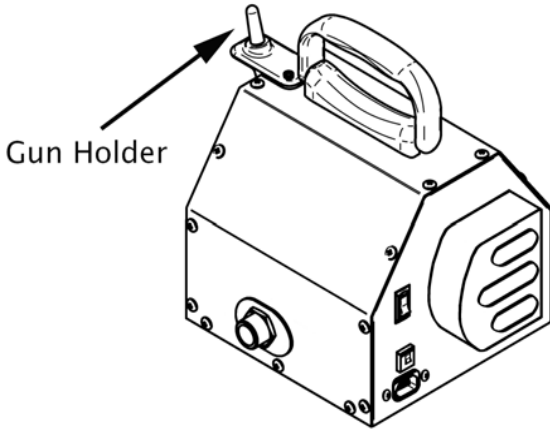

### GUN HOLDER INSTALLATION

The 2 holes on the top of the Holder require the 2 Machine Screws and Washers. These Screws fit into Threaded Inserts in the Metal Case. Do not over tighten - snug is fine.

The single Silver-Colored Screw must be installed to the single hole on the side of the Gun Holder. Once again, please do not over tighten this screw - snug is fine.

If you do not intend on using the Gun Holder you may insert the appropriate screws (as mentioned above) to block the holes.

### GUN HOLDER USE

Place the Hose Connector (base of the Gun Handle) over the shaft of the Gun Holder shown in above illustration. Please ensure it is fully set down to the base of the shaft. The Spray Gun will now sit stationary. The Gun can be left on the Holder for any length of time. It is a convenient resting place between spraying and ideal for filling the Gravity Cup.

## ***For SERVICE & PARTS***

### ***USA***

#### **Cogent Bathtub Refinishing Coatings**

Phone: 862-238-7224    **Online:** [www.cogentcoatings.com](http://www.cogentcoatings.com)

#### **hvlp.net**

Phone: 800-650-0930    **Online:** [www.hvlp.net](http://www.hvlp.net)

#### **Phelps Refinishing**

Phone: 800-377-5662    **Online:** [www.phelpsrefinishing.net](http://www.phelpsrefinishing.net)

#### **Paint Sprayers Plus**

Phone: 877-293-5826    **Online:** [www.paintsprayersplus.com](http://www.paintsprayersplus.com)

### ***CANADA***

#### **Fuji Spray**

Phone: 800-650-0930    Local: 416-650-1430

#### **hvlp.ca**

Phone: 800-650-0930    **Online:** [www.hvlp.ca](http://www.hvlp.ca)

### ***UNITED KINGDOM***

#### **Axminster Power Tool Centre.** Axminster, Devon, England

Phone: 01297 33656    **Online:** [www.axminster.co.uk](http://www.axminster.co.uk)

### ***AUSTRALIA & NZ***

#### **Spraychief Industries** Campbellfield, Victoria 3061

Phone: 03-9357-8788    **Online:** [www.spraychief.com.au](http://www.spraychief.com.au)

### ***PUERTO RICO***

#### **Eagle Tools Mfg. Corp** San Lorenzo, Puerto Rico, 00754

Phone: 787-736-0444

#### **Fra-Marson Warehouse Distributors.** San Juan PR, 00926

Phone: 787-761-4810

### ***RUSSIA***

#### **varnishop.ru** St. Petersburg, Russia

Phone: 812-242-8040    **Online:** [www.varnishop.ru](http://www.varnishop.ru)

Copyright © 2014 Fuji Spray® Toronto. Canada

## Fuji Limited 2 Year Warranty

Fuji Industrial Spray Equipment Ltd. (“Fuji”) provides a 24 month limited warranty on the product to the original purchaser effective from the date of purchase against defects in materials and workmanship.

The warranty does not cover damage or defects arising as a result of abuse, misuse, accident, negligence, malfunction, corrosion, normal wear and tear, inadequate or lack of spray gun or other aspects of maintenance of the product, damage arising from improper assembly, installation or operation, or damage arising from the product being used for a purpose other than that for which it was designed or intended. The warranty is void if repairs to the product are made or attempted by anyone other than Fuji or its authorized agent, or if any modifications to the product are made or attempted.

Purchasers located in North America must obtain a Return Material Authorization number by calling Fuji at 1-800-650-0930 before returning the product to Fuji or its designated representative.

Purchasers located outside North America must contact the vendor from which they purchased the product. In all instances purchasers must return the product together with proof of purchase and with shipping prepaid. For valid warranty claims the product will be returned to the purchaser with shipping prepaid.

**This is the only warranty provided by Fuji with respect to the product and is in lieu of any other warranties, express or implied, including but not limited to any warranty of merchantability or fitness for a particular purpose. Fuji’s sole obligation under this warranty shall, at its option, be to either repair or replace a product determined by Fuji to be defective. In no event shall Fuji be liable for loss or profits, incidental or consequential damages, injury to any person or property, or any other damages of whatsoever nature.**